

# **EZ ELECTRIC POWER STEERING**

## **INSTALLATION INSTRUCTIONS**

**VOLVO AMAZON (120)**

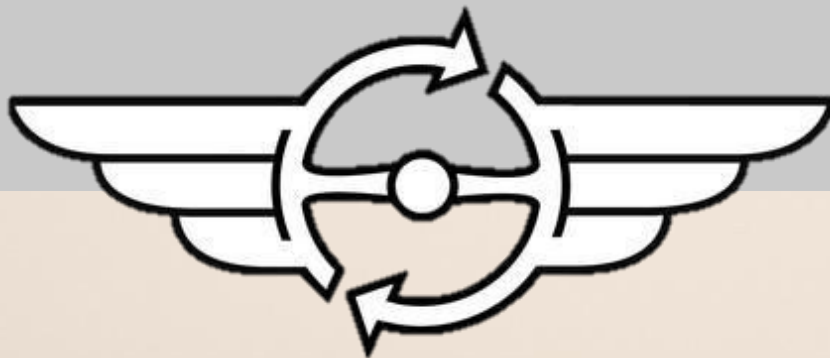



# CONTENTS

The Product .....	1
Contents of the set .....	2
Before and after assembly .....	3
Installation.....	4

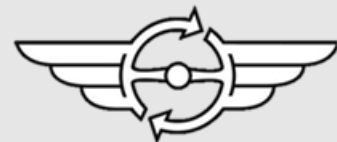

## THE PRODUCT

Thank you for choosing an EZ ELECTRIC POWER STEERING system for its quality, certification and easy assembly. Since 2006 we produce complete steering columns with integrated power steering. All columns are tailor-made for each type of car and we already have 200 types in stock! For more information about our products (power steering systems and replica steering wheels) or to place an order, please visit our website [www.ezpowersteering.nl](http://www.ezpowersteering.nl) or send an e-mail to [info@ezpowersteering.nl](mailto:info@ezpowersteering.nl). If you have any questions about the installation, please contact us at [workshop@ezpowersteering.nl](mailto:workshop@ezpowersteering.nl).

Version **C1.1**

Date **01-04-2026**

*This manual should be read carefully to avoid errors. Check whether all parts of the set are present. This can be done on the basis of the picture in this manual.*

*Before installation, compare the EZ POWER STEERING column with the original column. Check that the dimensions are the same. Also fit the steering wheel to the column.*

*If you do not have the skills or tools to perform the installation, have it performed by a professional. EZ POWER STEERING cannot be held liable for incorrect installation or self-inflicted damage.*

*The manuals are generally based on a left-hand-drive vehicle. In most cases, the right-hand drive version is the mirror image of the installation of a left-hand drive vehicle.*

*If you think that any changes are needed in this manual, we would like to receive your pictures and comments. With your feedback we can improve our manuals!*

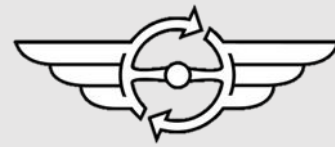

# CONTENTS OF THE SET

## 03.V.036 – Volvo Amazon (Safety) EZ-kit

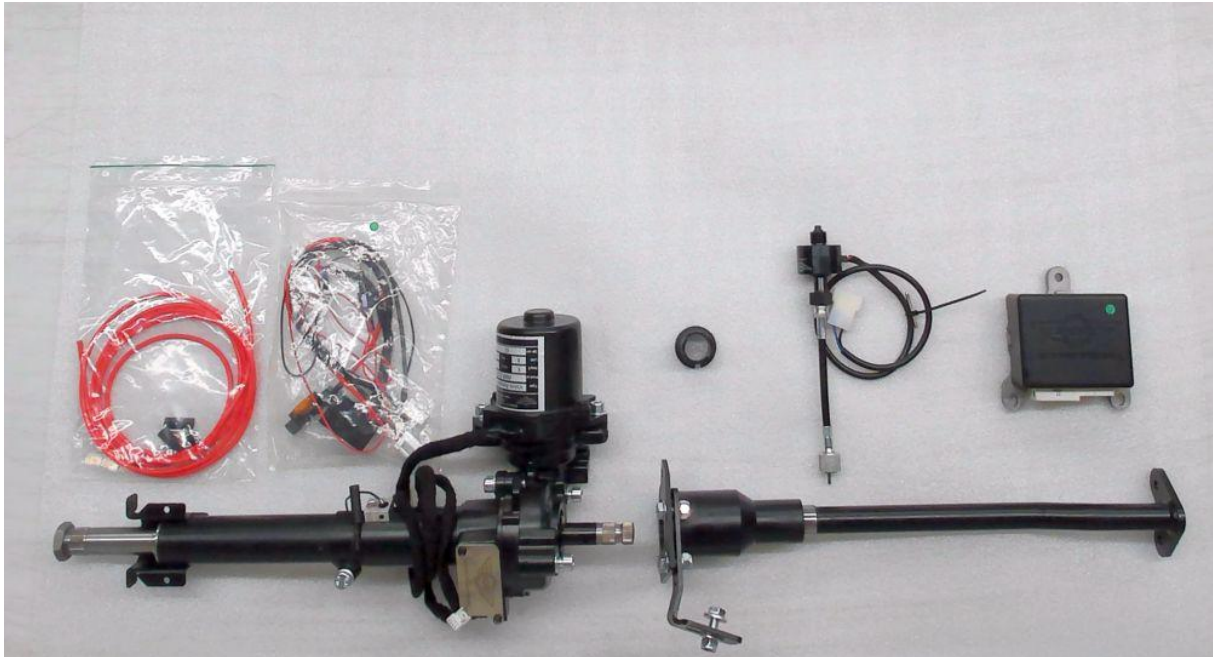

## 03.V.037 – Volvo Amazon (T-bar) EZ-kit

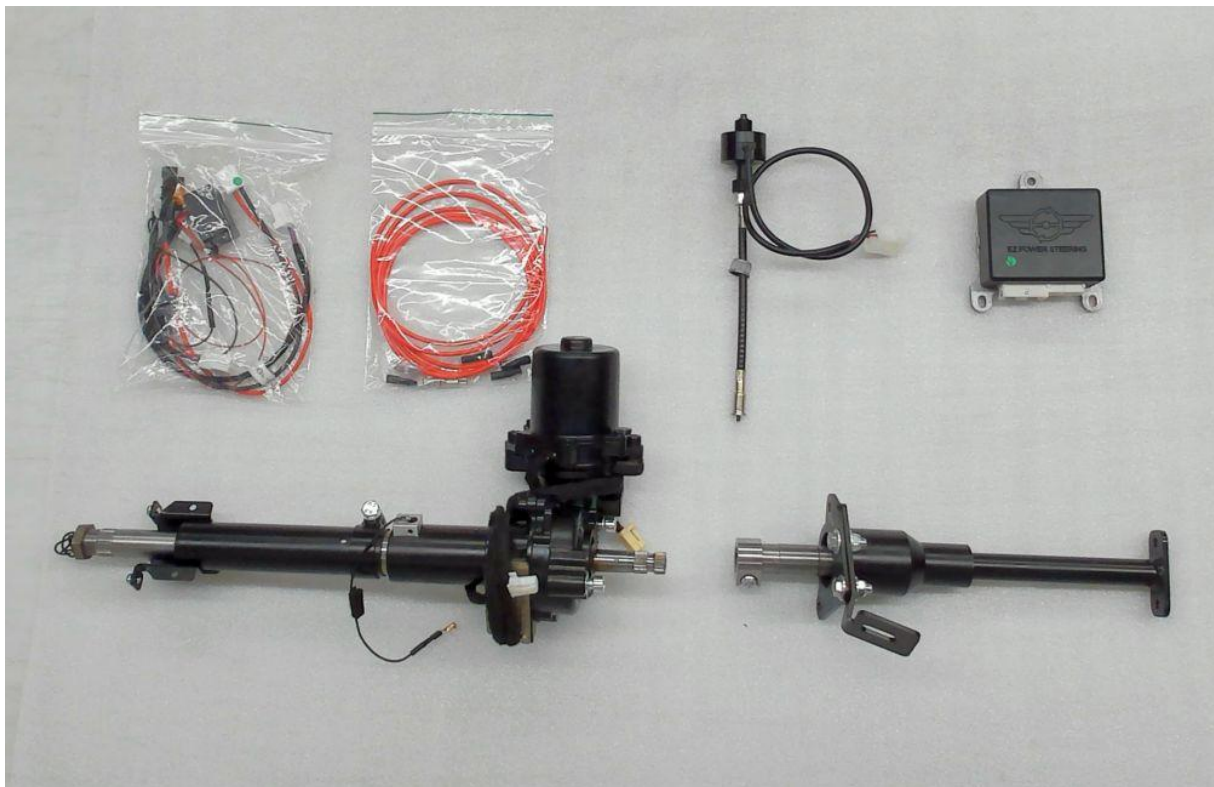

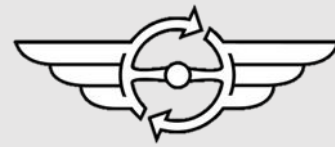

# BEFORE AND AFTER ASSEMBLY



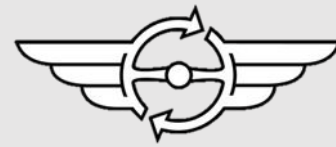

# INSTALLATION

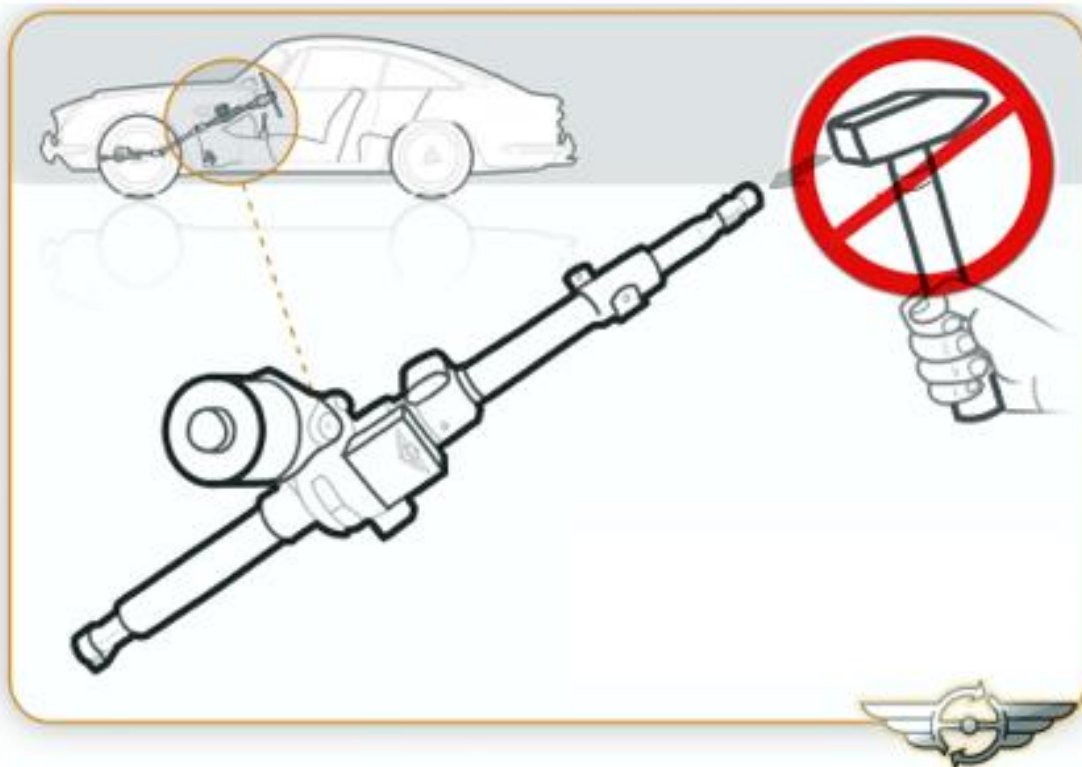

Never hit the input shaft with an object during or after installation. This can negatively affect the sensors.

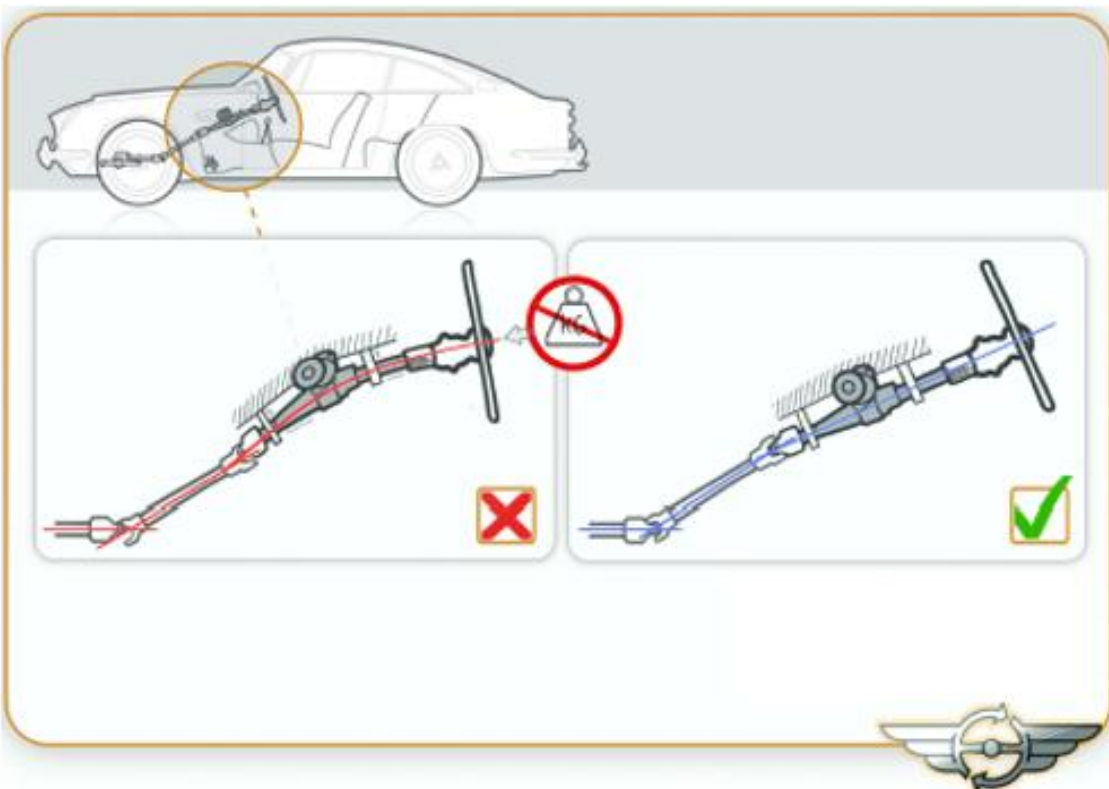

The steering system must always be fitted tension free and properly aligned.

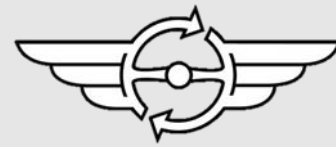

## Check length, diameter and splines

Compare the EZ Power Steering Column (EZ-unit) with the original steering column before installing it. The total length of the EZ unit may differ slightly from that of the original steering column to make installation easier. Check if the splines on the top and bottom, the diameter of the steering tube and the length of the column are all the same as the original steering column. When in doubt you can use the original steering wheel to check the top splines for fit. Never hammer on the steering shaft of the EZ unit!

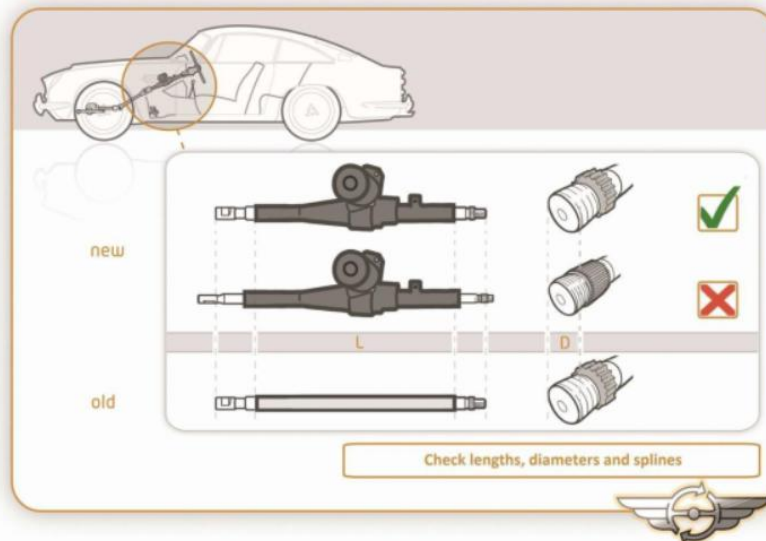

In the car industry it's common to have some small tolerances in spline connections. In very exceptional cases connecting a new shaft from the EZ-unit in the original (old) U-joint could cause a tight fitting. This is sometimes relatively easy to solve by sanding only about 0,2mm (0,007 inch) in the inner part of the U-joint and also the spline on the output shaft on the EZ-unit.



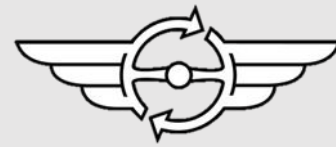

## Torque tightening values in Nm.

When the new steering column is being fitted hand tighten all the bolts and check if everything turns smoothly before tightening to required Torque, use torque tightening table below:

	strength class 8.8	strength class 10.9	strength class 12.9
Bolt M6	11	16	19
Bolt M8	27	40	47

The system works with a torsion bar into the unit, this measures the amount of torque/load on the steering shaft while steering, the torque sensor measures this and sends a voltage to the ECU. The ECU uses this signal together with the speed signal to control the electric motor from the EZ-unit.

## Voltage

The basic EZ-unit, is a 12V system with negative earth! There are extra wiring sets available, so that the kit will work with a 6V or 24V system and/or positive earth. Check your vehicle setup before fitting the EZ-unit.

The red supply wire (30+) has to be connected directly to the starter relay or the plus terminal of the battery and fused with the supplied 40 Ampere fuse.

Connect the black ground wire (31-) cable eyelet to a suitable earth point (not to the column). If you have a positive earth car (Plus battery terminal connected to the chassis) ensure that you have the correct wiring loom with additional relay

The thin red wire is ignition switched (15+) and should be connected to a fused contact switched power supply. Check the voltage between the ignition switched plus against earth, with switched on ignition, this must be at least 11,5 Volt. If it drops below this the electric power steering will switch off. (When this happens during driving, the vehicle will drive similar as before the EZ conversion).

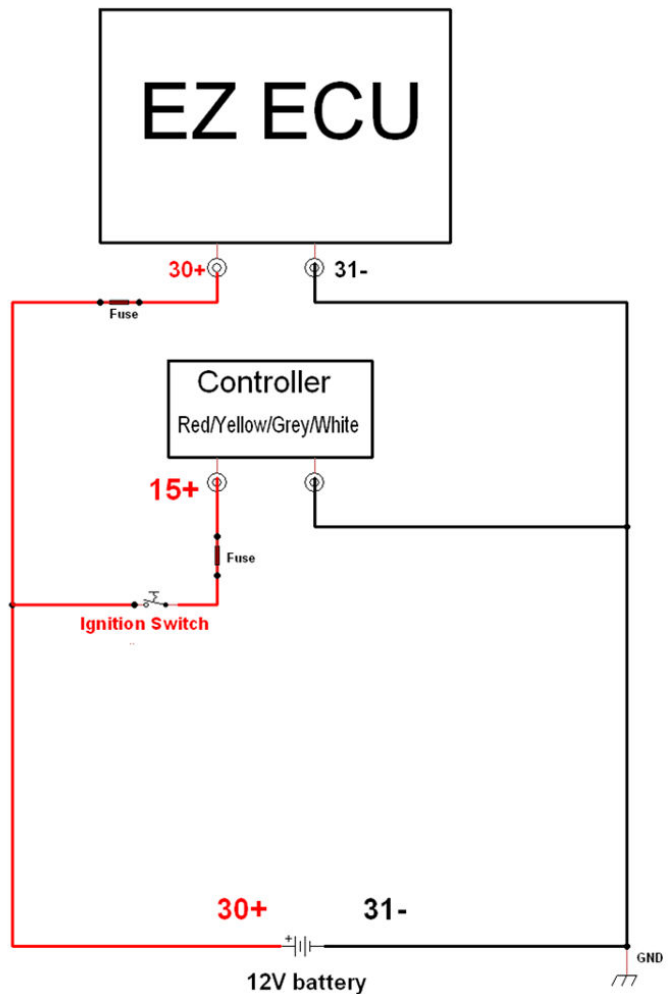

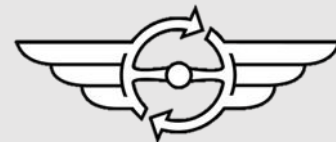

Be sure to measure the voltage under load (with other electrical devices switched on like: cooling fan, windshield wiper or electric window defroster, etc.) and with running engine.

If needed there are electrical devices available, to maintain the correct ignition switched voltage above 11.5V!

Also a simple test of the electronics is to check if you hear a click after switching on the ignition, another click should be heard after 1 or 2 seconds after switching off the ignition

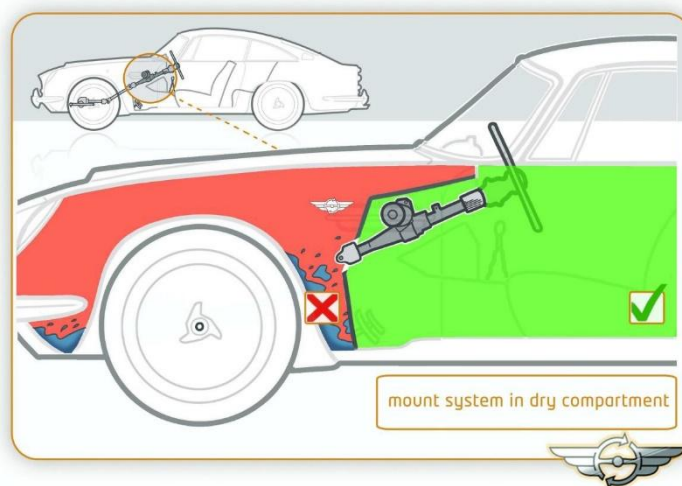

The EZ unit, wiring loom, ECU and other electric components may not be exposed to high temperatures (60 degrees centigrade or higher) or a wet environment.

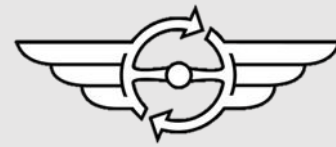

### Step 1.

Inspect the tyre pressure and test drive the car. Check that the steering wheel self-centers. Exeman that the steering and instruments are not defective. If everything this is in order, proceed with the conversion.



### Step 2.

Find a fused power supply switched via the ignition. This is necessary for the power supply of the EZ powersteering unit (see step 17). The switched power supply can either be taken from the ignition switch or from the fuse box. Then disconnect the battery negative terminal lead.

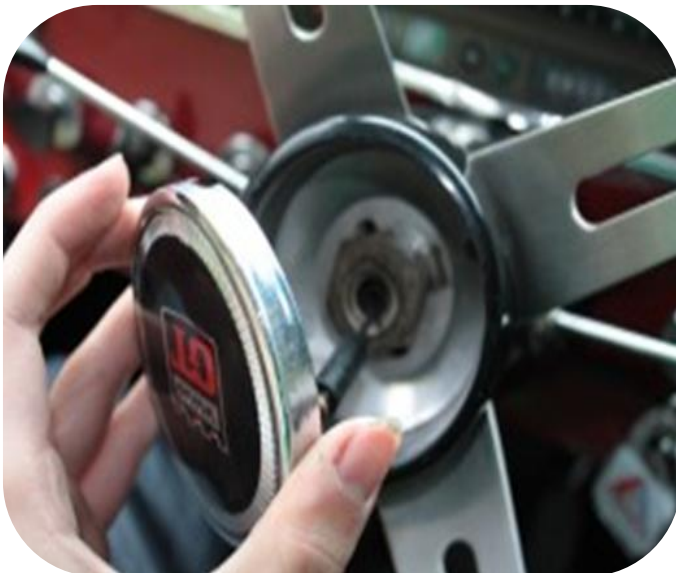

### Step 3.

Remove horn button and cut the wire. The wire now can be pulled out at the steering box.

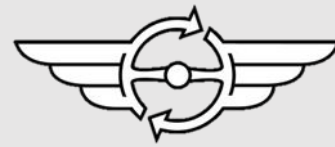

#### Step 4.

Remove the steering wheel with the cover and switches. Depending on the model, the ignition lock needs to be removed.



#### Step 5.

Measure the distance from the input shaft against the original steering tube and against the dashboard. Write them down.

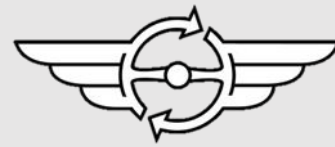

### Step 6.

Disconnect the steering shaft coupling in the engine compartment.

### Step 7.

The steering shaft needs to be pulled out towards the front (towards the engine compartment). The tube must be removed by unscrewing the two bolts.



### Step 8.

Feed the output shaft through the bulkhead together with the mounting bracket.

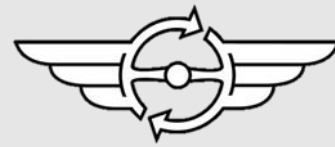

### Step 8a.

If a retaining lip protrudes through the tube, it must be trimmed.

### Step 8b.

Position the EZ unit behind the dashboard, feed the input shaft through the bulkhead and connect the output shaft. The input tube can be slid over the input shaft together with the mounting clamp.



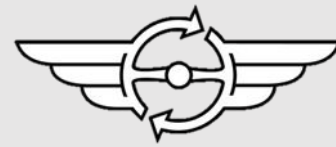

### Step 9.

Secure the connection of the output shaft on the motor side by fitting the clamp and tightening the Torx clamping bolt to 40 Nm. On the other side, the output shaft can be connected to the shaft leading to the steering gear.

### Step 10.

The mounting bracket can be attached to the existing original hole already present in the bodywork. If present, remove the original rubber cap



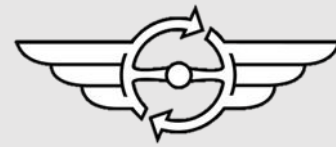

### Step 11.

On models without a steering lock, the front support of the input tube can be removed.

### Step 12.

Locate a suitable location for the ECU and install it. Connect the EZ wire set to the ECU.

### Step 13.

Remove the cable from the speedometer and install the speed sensor on it. The cable can be reinstalled on the sensor.

### Step 14.

Reinstall the steering column switch on the EZ unit. Guide the original wire from horn, through the firewall, to the EZ unit and connect it with the contact ring wiring.

### Step 15.

Connect the thick red wire (30+) from the fuse holder directly to the positive battery. It is advisable to extra isolate the wire.



### Step 16.

Connect the thin red wire (15+) to a fused ignition contact switched power supply (see point 2)

### Step 17.

Connect the black wire (31-) to a suitable clean ground point.

### Step 18.

Connect the previously disconnected battery negative terminal lead. After switching on the ignition a click can be heard from the ECU, the system is now operational, check this by making steering movements. After switching off the ignition a click is heard again after about 3 seconds. The system is now switched off.

### Step 19.

Take a test drive and check all systems again. Also check if the position of the steering wheel is correct, if not adjust it. Make sure there is enough length on the horn wire for the possible adjustment of the steering wheel.