

EZ ELECTRIC POWER STEERING

INSTALLATION MANUAL

ALFA ROMEO 4C

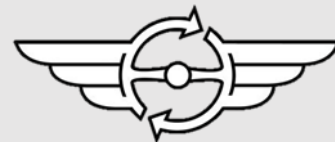



CONTENTS

The Product	1
Contents of the set.....	2
Before and after installation	3
Installation.....	4

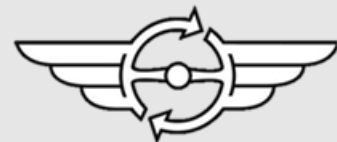

THE PRODUCT

Thank you for choosing an EZ ELECTRIC POWER STEERING system for its quality, certification and ease of installation. Since 2006, we have been manufacturing complete steering columns with integrated power steering. All columns are custom-made for each type of car and we already have 200 types in stock! For more information about our products (power steering systems and replica steering wheels) or to place an order, visit our website www.ezpowersteering.nl or send an email to info@ezpowersteering.nl. If you have any questions about installation, please contact us

at workshop@ezpowersteering.nl.

Version C1.0

Date 30-04-2026

This manual must be read carefully to avoid errors. Check that all parts of the kit are present. This can be done by referring to the photo in this manual. Before fitting, compare the EZ ELECTRIC POWER STEERING column with the original column. Check that the dimensions are the same. Also fit the steering wheel to the column.

If you do not have the skills or tools to carry out the installation, have it done by a professional. EZ ELECTRIC POWER STEERING cannot be held liable for incorrect installation or damage caused by the user.

The manuals are generally based on a left-hand drive vehicle. In most cases, the right-hand drive version is the mirror image of the installation for a left-hand drive vehicle.

If you think changes are needed to this manual, we would be grateful to receive your photos and comments. Your feedback helps us improve our manuals!

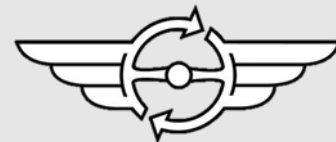

CONTENTS OF THE SET

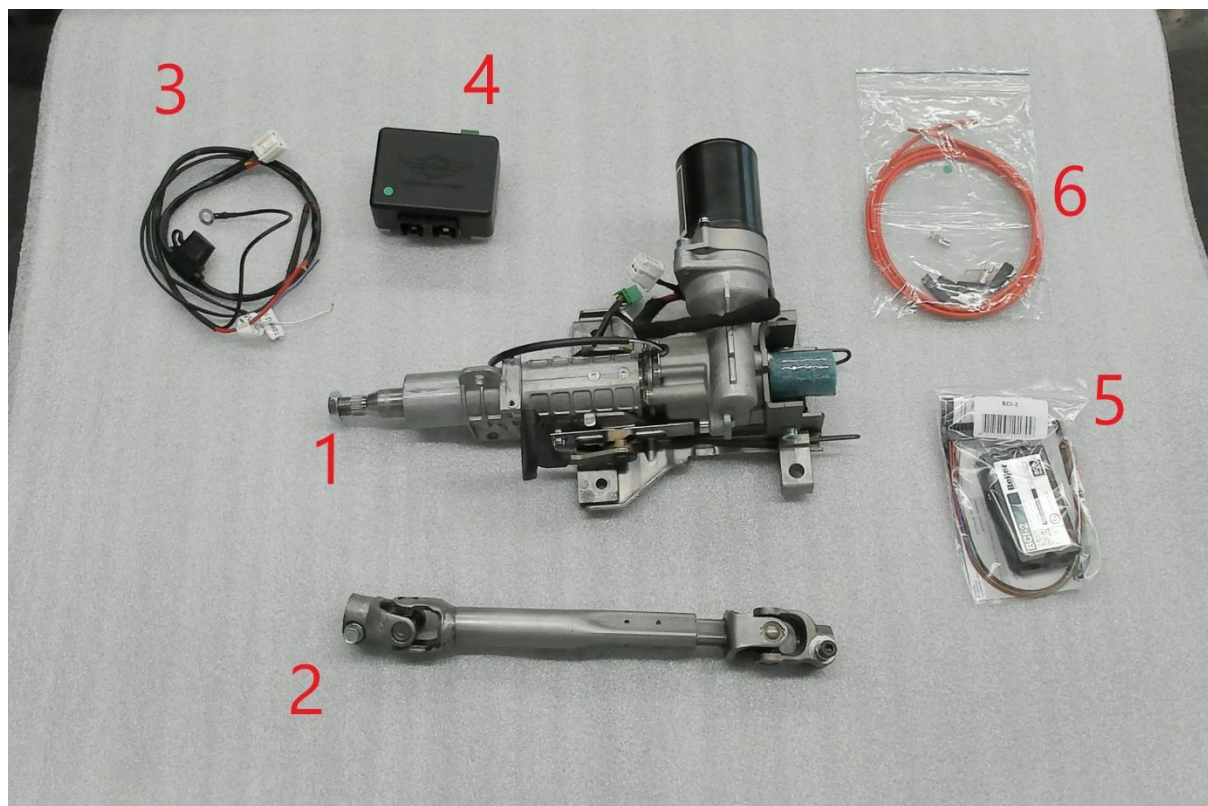

03.A.014 - 1 EZ Set

03.A.014 - 2 Output shaft

03.A.014 - 3 Cable set + potentiometer (standard)

03.A.014 - 4 ECU

03.A.014 - 5 BCI-6 converter (optional)

03.A.014 - 6 Power cable

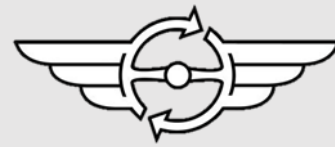

BEFORE AND AFTER INSTALLATION



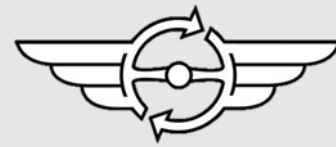

INSTALLATION

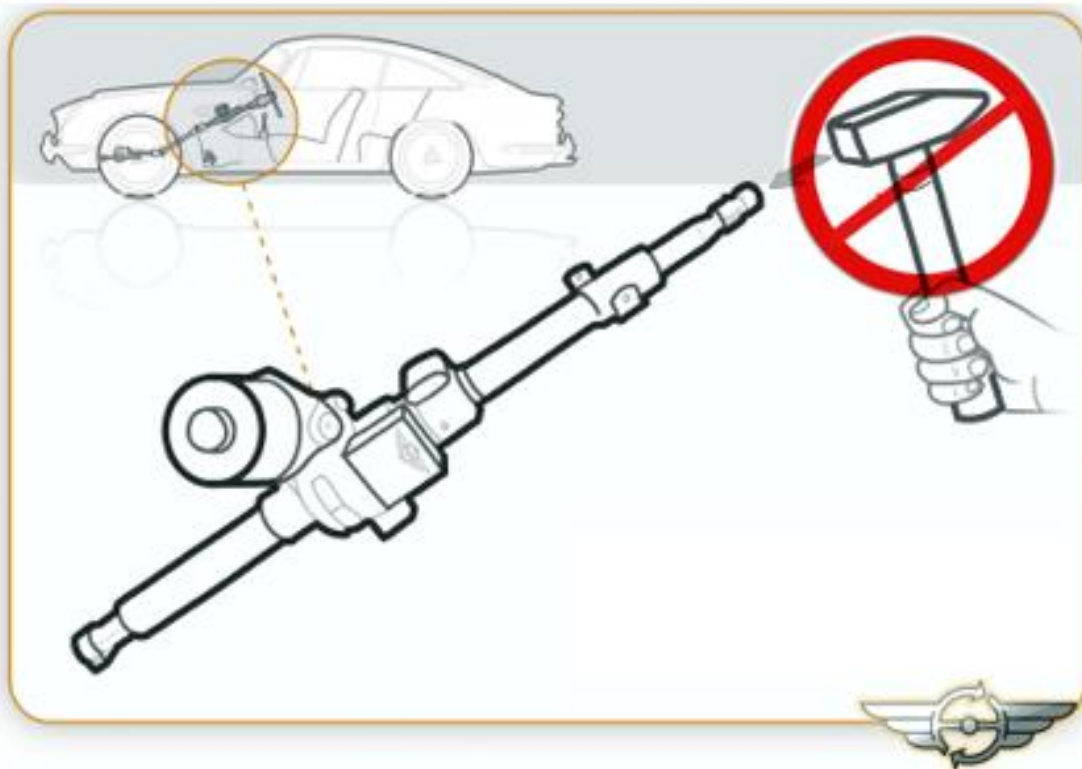

The steering mechanism must always be correctly aligned and installed without tension.

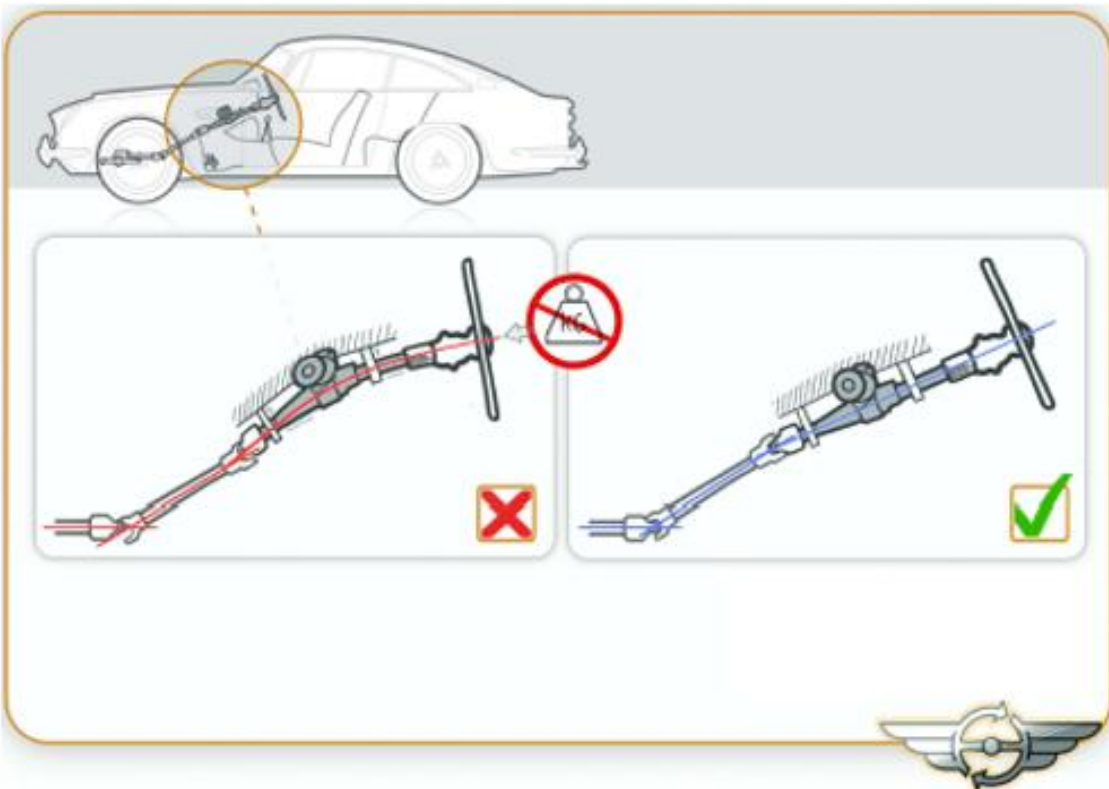

Never strike the input shaft with an object during or after installation. This may adversely affect the sensors.

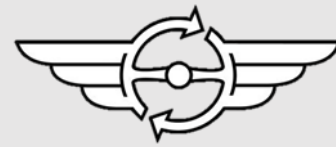

Check length, diameter and splines

Compare the EZ power steering column (EZ unit) with the original steering column before fitting it. To facilitate installation, the total length of the EZ power steering unit may differ from the total length of the original steering column. Check that the splines at the top and bottom, the diameter of the steering tube and the length of the column are all the same as the original steering column. If in doubt, you can use the original steering wheel to check whether the upper splines fit.

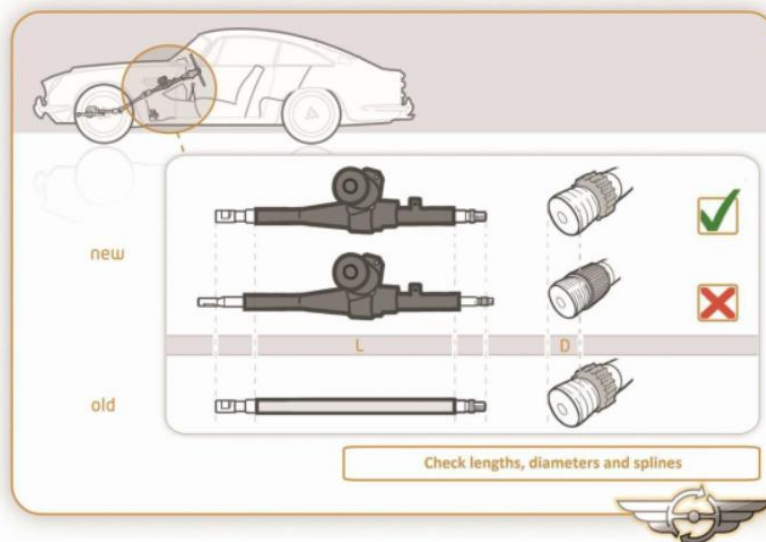

In the automotive industry, it is common to have small tolerances in spline connections. In very rare cases, fitting a new shaft from the EZ unit into the original (old) universal joint may result in a tight fit. This can sometimes be resolved relatively easily by sanding down approximately 0.2 mm (0.007 inches) from the inner part of the universal joint and also from the spline on the output shaft of the EZ-unit.



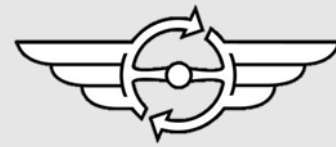

Tightening torques in Nm.

Once the new steering column has been fitted, tighten all bolts by hand and check that everything turns smoothly before tightening the bolts to the required torque; use the torque table below for this:

	Strength class 8.8	Strength class 10.9	Strength class 12.9
M6	11	16	19
M8	27	40	47

The system uses a torsion bar within the unit; this measures the amount of torque/load on the steering shaft whilst steering. The torsion sensor measures this and sends a voltage signal to the ECU. The ECU uses this signal, together with the speed signal, to control the electric motor of the EZ unit

Voltage

The basic EZ-unit is a 12V system with negative earth! Additional wiring kits are available so that the kit also works with a 6V or 24V system and/or positive earth. Check your vehicle's configuration before fitting the EZ-unit.

The red power wire (30+) must be connected directly to the starter relay or the positive terminal of the battery and fused with the supplied 40-amp fuse.

Connect the black earth wire (31-) to a suitable earth point (not the column). If you have a car with positive earth (battery positive terminal connected to the chassis), ensure you have the correct wiring harness with an additional relay.

The thin red wire is ignition-switched (15+) and must be connected to a fused, ignition-switched power supply. Check the voltage between the switched positive and ground, with the ignition on; this must be at least 11.5 volts. If this

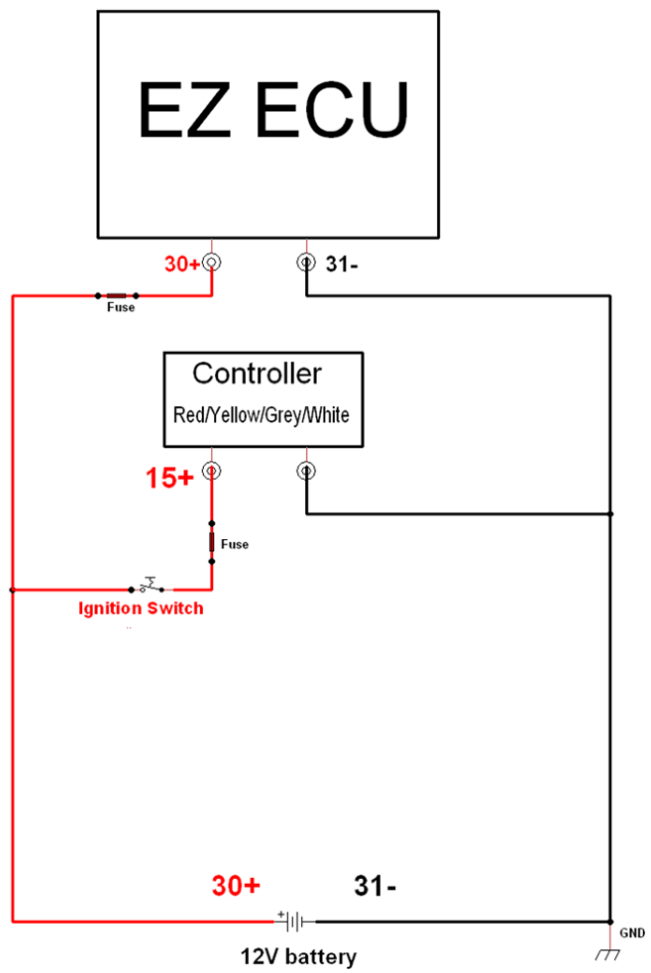

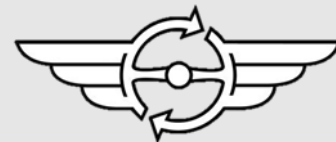

this value, the electric power steering will switch off. (If this happens whilst driving, the vehicle will drive just as it did before the EZ conversion). Ensure you measure the voltage under load (with other electrical devices switched on such as: cooling fan, windscreen wipers or electric windscreen defroster, etc.) and with the engine running.

If necessary, electronic devices are available to maintain the correct ignition-switched voltage above 11.5V!

A simple test of the electronics is to check whether you hear a click after turning the ignition on; another click should be audible 1 or 2 seconds after turning the ignition off

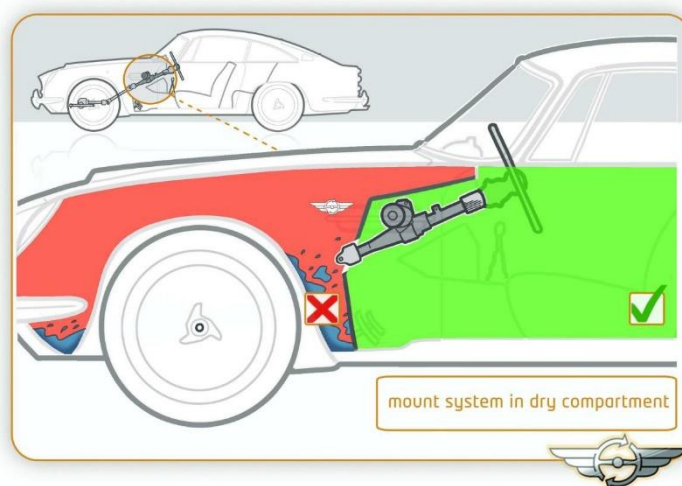

The EZ unit, wiring harness, ECU and other electrical components must not be exposed to high temperatures (60 degrees Celsius or higher) or a wet environment.



Step 1.

Check the tyre pressure and take the car for a test drive. Check that the steering wheel returns to the straight-ahead position. Check that the steering and instruments are working properly. Is everything in order? If so, proceed with the conversion.

Step 2.

Locate a fused, ignition-switched power supply. This is required to power the EZ Power Steering unit. If you have a CANBUS converter, the ignition-switched power supply and the speed signal are supplied via this converter (see the appendix for the diagram).

Set the wheels and steering wheel to the straight-ahead position and then proceed with the conversion.

Step 3.

Switch off the ignition and disconnect the negative terminal of the battery. The steering airbag must be removed for this conversion. The airbag system must be **disconnected from the power supply for at least 15 minutes** to fully discharge.

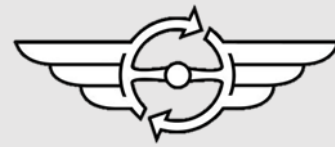

Step 4.

Set the steering wheel to the straight-ahead position, mark this on the bulkhead, and then loosen the bolt on the universal joint.

Step 5.

Remove the covers behind the handlebars.

Step 6.

Use a flat-bladed screwdriver approximately 65 mm long to press the two clips into the holes at the 7 o'clock and 4 o'clock positions to release the airbag. If necessary, secure the steering wheel with tape.

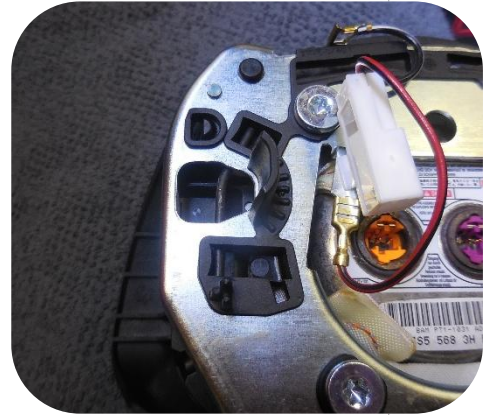

Step 7.

Disconnect the two airbag connectors, the horn connector and, if applicable, the shift paddle connectors.

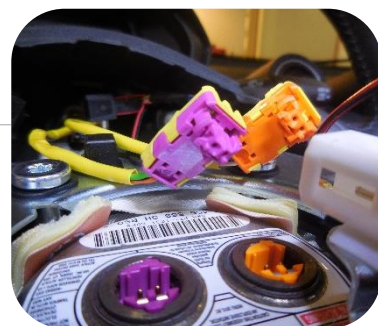
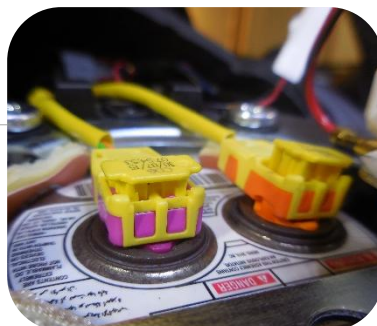
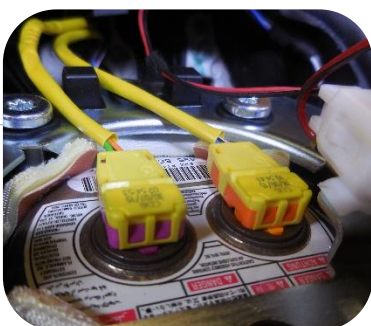

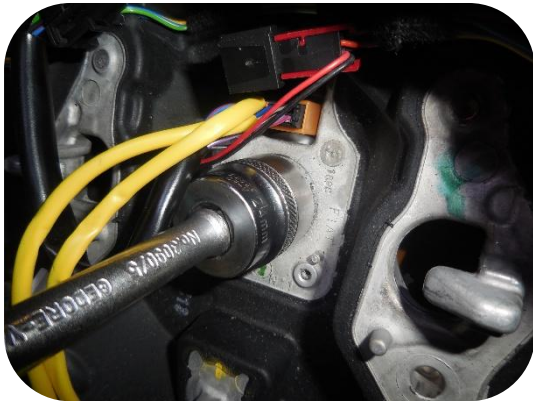
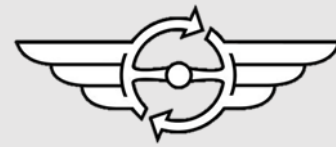

Step 8.

Mark the position of the steering wheel relative to the axle and remove the large fixing nut.

Step 9.

Carefully pull the steering wheel. If necessary, use a steering wheel puller and take care with the cables.

Step 10.

Secure the airbag slip ring with tape. Attention, it may **not** be twisted.

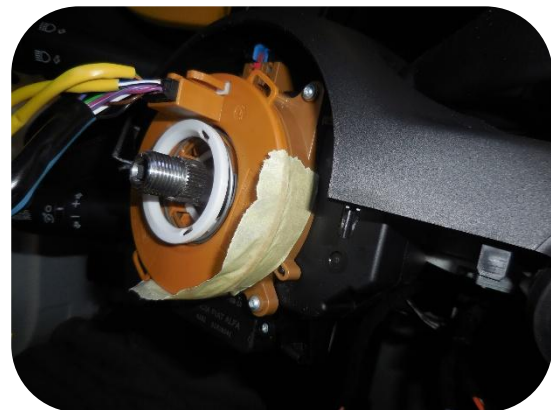

Step 11.

Take photos of all the connectors attached to the steering column. Mark them so that everything can be put back correctly later. Then disconnect all the connectors.

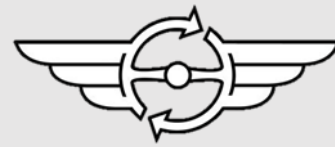

Step 12.

Loosen the four nuts securing the steering column. Remove the steering column from the car.



Step 13.

Transfer all the attachments from the original column to the EZ power steering column.



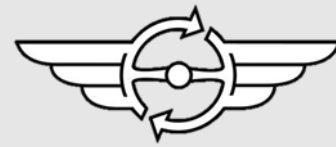

Step 14.

Once all the parts have been transferred, the EZ power steering column can be fitted to the car. The remaining parts can then be refitted, a small recess in the plastic cover is needed.

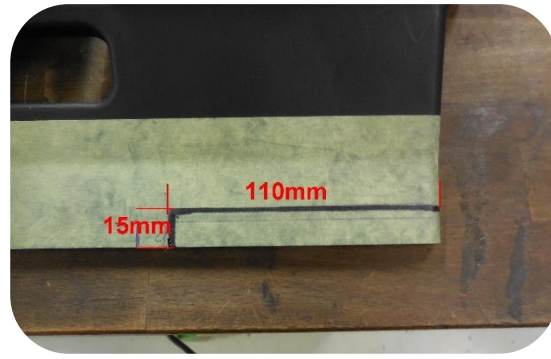

Step 15.

Fit the steering wheel in the marked straight-ahead position.

Step 16.

Find a suitable location for the ECU and install it. Then connect the EZ wire set.

Step 17.

Connect the thick red wire supplied (30+) directly to the battery positive terminal via the fuse holder. It is advisable to insulate the wire with an extra sheath.

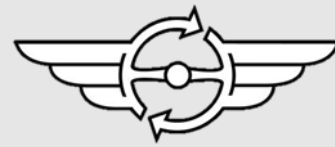

Step 18.

Connect the thin red wire (15+) to a fused, switched power supply (see step 2).

Step 19.

Connect the black wire (31-) to a suitable clean earth point.

Step 20.

Reconnect all the original plugs

Step 21.

Reconnect the connectors to the airbag and click the airbag back into the steering wheel.

Step 22.

Reconnect the battery ground cable that was previously disconnected. After turning on the ignition, you will hear a click from the ECU; the system is now operational. Check this by turning the steering wheel. After turning off the ignition, you will hear another click after approximately 4 seconds. The system is then switched off.

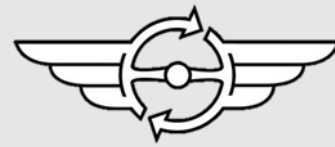

Step 21.

The end result.



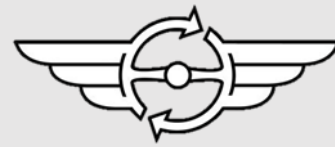

Appendix:

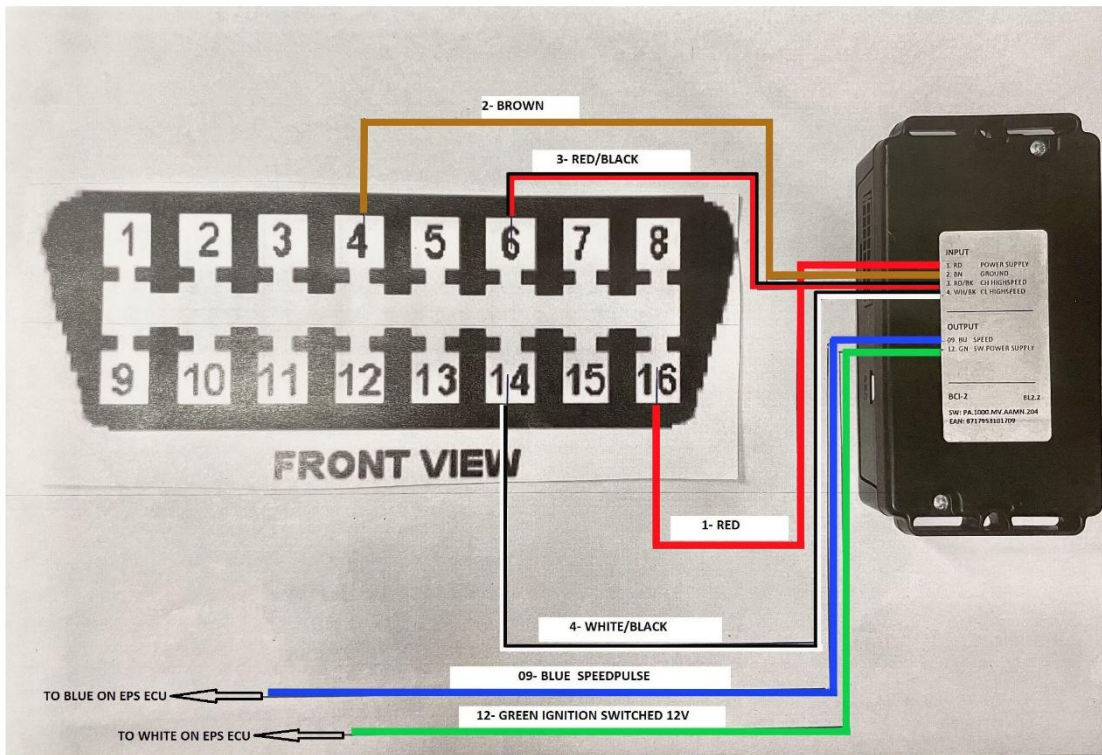

Alfa Romeo 4C - BCI-6 special connection
26.146.0029

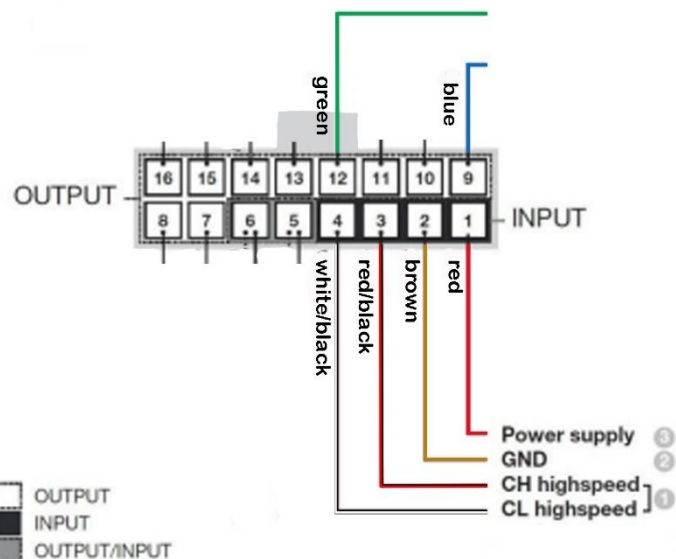
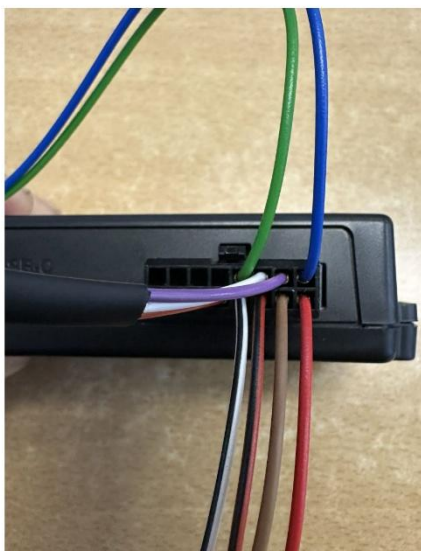

EZ ELECTRIC POWER STEERING

